

## Quick-Drain Installation Requirements

---

Installation of the Quick-Drain-QF and Quick-Drain-HF™ Fluid Management Systems is a straightforward process.

These installation instructions are written in a general terms and require that the installer modify them appropriately in order to meet state and local plumbing codes and federal, state, and local regulations for the disposal of medical fluid waste.

### **WARNING:**

It is the responsibility of the hospital to ensure that any necessary permits are acquired and that all state and local plumbing codes are followed. In addition, it is the responsibility of the hospital to ensure that medical fluid waste is handled and disposed of in accordance with all federal, state, and local regulations, without limitation, those pertaining to human health, safety, and the environment.

### **Facility Requirements**

For proper performance and installation, the Quick-Drain Systems require:

- ◆ Water pressure between 40-60 psi supplied by a 1/2" pipe to operate optimally
- ◆ an area of open wall space per figure 1
- ◆ a wall area capable of bearing a 150 lb. static load
- ◆ a Watts Double Check Reduced pressure backflow preventer on the inlet water line
- ◆ a minimum 1" sanitary waste line

### **Tool Requirements**

With the facility requirements met, the Quick-Drain can be installed using standard plumbing tools.

### **Material Requirements**

Typical materials and fittings needed to install the Quick-Drain include:

- ◆ Trap
- ◆ Cleanout
- ◆ Ball valves
- ◆ Various piping and fittings
- ◆ Screws or bolts to support a 150 lb. static load

However, a facility may require additional materials depending on the features of the installation site.

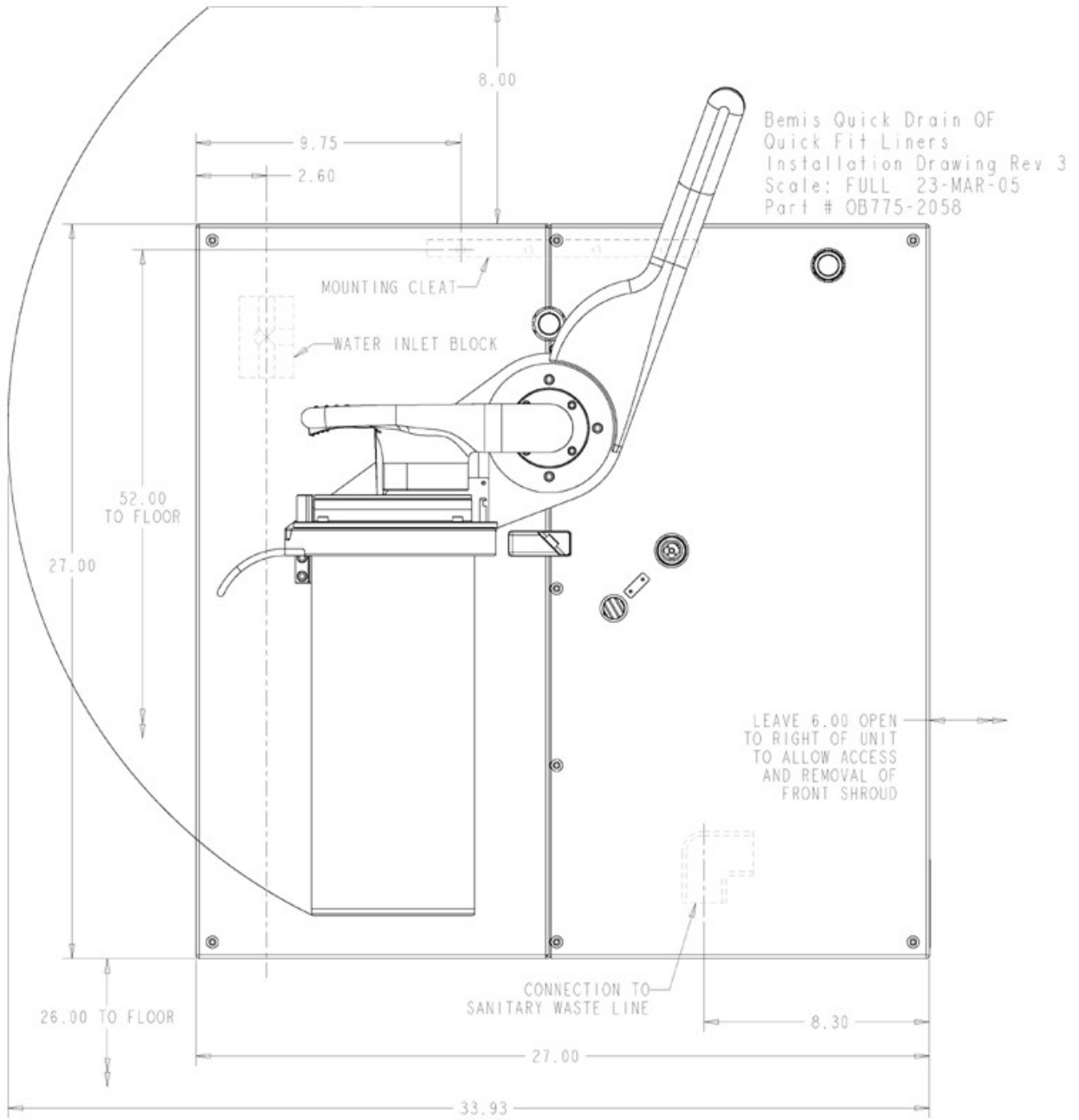

Figure 1: Quick-Drain-QF Installation Dimensions

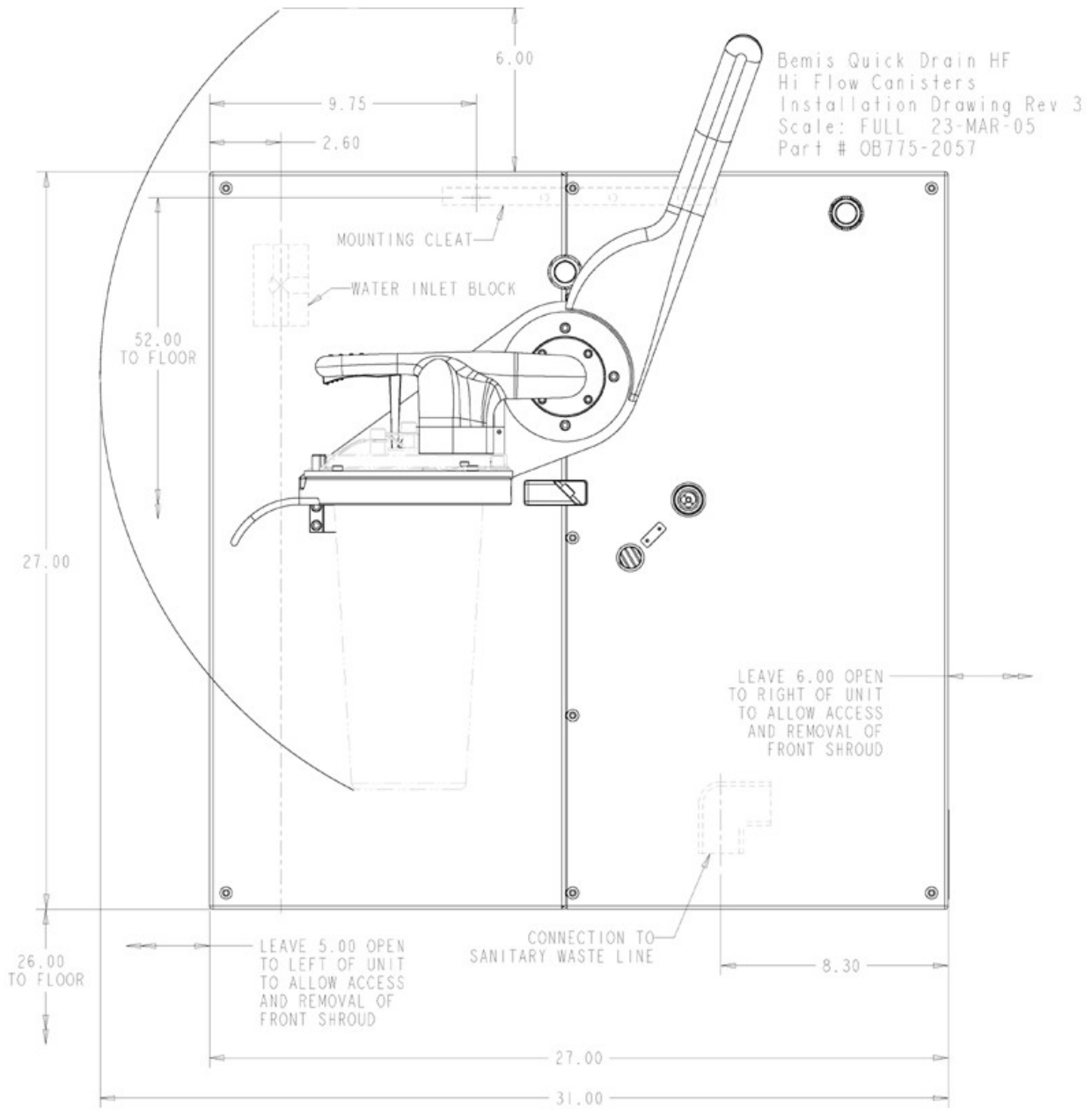

Figure 2: Quick-Drain HF Installation Dimensions

## **Installation Steps For Quick-Drain QF and Quick-Drain HF**

*CAUTION: Before beginning the installation, make sure that all affected water lines have been turned off.*

1. Select a place for the Quick-Drain to be installed, preferably an area isolated from patient contact and treatment. Refer to Figure 1 or 2 (depending on model) for typical dimensions used and the required wall footprint.
2. If not already in place, a Watts double check valve reduced pressure backflow preventer must be installed on the water supply line to the Quick-Drain.
3. Open the shipping crate of the Quick-Drain. Remove all of the internal bracing and the cover from the box on the inside of the crate.
4. Take the component bag out of the box inside the crate. Remove the hanging cleat and mount as shown in Figure 1 or 2 (depending on model). Use appropriate fasteners so that the hanging cleat can support at least 150 lbs.

*NOTE: In some installations, it is beneficial to first install stringers or a backboard onto which the Quick-Drain may then be mounted. Ensure the handle and top clamp have enough room to move through their full ranges of motion.*

5. Hang the Quick-Drain on the hanging cleat. Use appropriate fasteners in the four corner holes of the backplate to secure the Quick-Drain to the wall.
6. Take the two-piece metal handle out of the box. Remove the fasteners that hold the two pieces together. Align the two handle parts over the swing arm as shown in Figure 3. Use the fasteners that originally held the handle pieces together to hold the handle pieces to the swing arm.

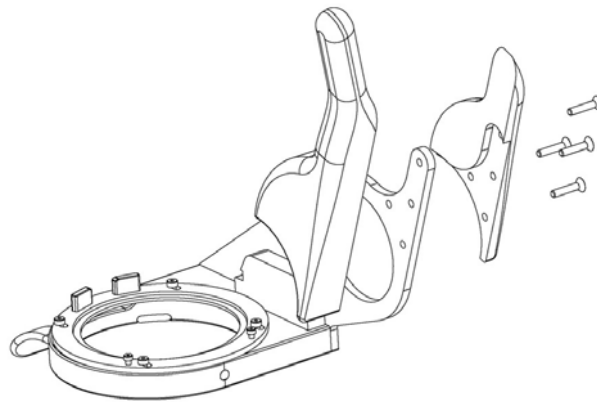
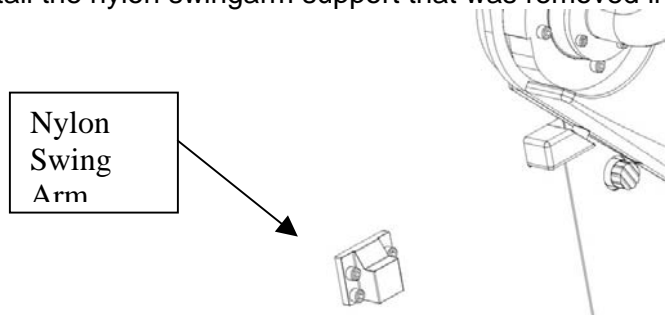

Figure 3: Handle Assembly

7. A 1/2" water line can be run to the Quick-Drain from the top or bottom of the machine. (Reference Figure 1 or 2) When running the water line to the machine, place a water valve just before the Quick-Drain so that water can be turned off to the system if needed.
8. When attaching the water line to the inlet water block, insert the provided plug in the unused water entry hole. Also move the bent stainless steel cover plate to cover the unused hole in the front shroud.
9. Connect the sanitary waste line to the 1" female PVC pipe fitting on the Quick-Drain. A cleanout trap should be installed between the Quick-Drain and sanitary waste line.
10. Turn on the water supply and check for any water leaks. If there are any leaks found, fix that leak before moving on in the installation process.
11. Depending on your system, fill either a Quick-Fit Liner or Hi-Flow Hard Canister with water and drain according to the operating instructions. Check for water leaks on all the water connections. If a leak is found, tighten the fittings until the leak is eliminated.
12. When the swing arm is in its home position, it will rest on a nylon swing arm support. Use an Allen wrench and remove the four cap screws and the nylon swing arm support. See Figure 4.
13. Take the left shroud and slide it onto the unit from the left side. It will slide behind the swing arm and fit around the aluminum back plate. The swing arm may have to be moved to allow the shroud to fit into position.
14. Re-install the nylon swingarm support that was removed in step 12.



**Figure 4: Nylon Swingarm Support**

15. Take two of the 1/4-20 button head socket cap screws from the component bag and fasten the left shroud to the back plate in the top left and bottom left corner. Also take two of the 8-32 x 3/8 flathead socket cap screws from the component bag and fasten the left shroud to the aluminum mounting block on the right edge of the shroud.
16. Take the right shroud and slide it onto the unit from the right side. It will overlap the edge of the left shroud. Take seven of the 1/4-20 button head socket cap screws from the component bag. Use two to fasten the shroud to the back plate in the upper and lower right corners. Use the remaining five to fasten the two shrouds together where they overlap in the middle of the unit. (See Appendix C, Figure 29 for reference on shroud assembly.)